

## SETTING UP YOUR LEE BREECH LOCK CHALLENGER PRESS

**1 MOUNT YOUR PRESS.** The most convenient way to mount your press is with our **Lee Bench Plate System #90251**. This system includes all of the mounting hardware and allows for quick press removal without unbolting from bench.

OR — purchase [qty. 3]  $\frac{1}{4}$ " or  $\frac{5}{16}$ " bolts and nuts and prepare your workbench for use with this press using drill template available: [leeprecision.com/files/instruct/TMPBLC.pdf](http://leeprecision.com/files/instruct/TMPBLC.pdf)



SCAN ME

FOR THOSE WITHOUT A BENCH, CONSIDER OUR **LEE RELOADING STAND #90688**

Both the #90688 Reloading Stand and #90251 Bench Plate include a steel mounting plate.



**LOCATE PARTS BLISTER PACK**

**FIG 1** Assemble bolt, heavy washer & lever clamp

**FIG 2** Slide lever clamp assembly into toggle and orient hole in lever with radius in toggle

**FIG 3** Slide the roller handle into the lever clamp assembly; making sure the handle passes completely through.

**FIG 4** Snug bolt with a  $\frac{1}{2}$ " socket or wrench; tighten securely to 25 ft./lbs. minimum

**IMPORTANT**

The toggle linkage operates on special aircraft type full body bolts and is retained with a crown lock nut. You can adjust the lock nut to eliminate any side play in the linkage.

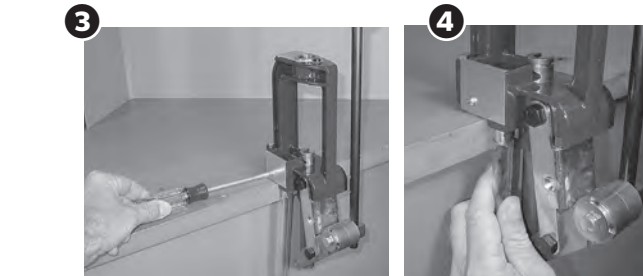

**3** Attach primer deflector with the #8 self-tapping screw provided.

**4** Install spent primer tube. Leave the cap on the tube if you are not routing to a trashcan.

The toggle linkage operates on special aircraft type full body bolts and is retained with a crown lock nut. You can adjust the lock nut to eliminate any side play in the linkage.

### YOUR PRESS FEATURES THE LEE BREECH LOCK QUICK-CHANGE DIEHOLDERS

Once dies are set you can instantly remove them and replace them to the exact same position. The Breech Lock includes a lock pin for initial die set up. If cost is more important than convenience, you can leave the quick lock bushing permanently installed and screw your dies in and out as in any conventional press.

Thread your die into a quick-change holder and lightly snug the lock ring.



Insert the holder into the press so that the lock groove will line up when secured. Adjust your die in or out for proper operation.



Remove the die by depressing the lock button and rotate the die  $\frac{1}{6}$  of a turn lift out and change to your next die.



Notice how the lock pin is automatically depressed allowing instant one-handed removal.

After dies are set, they can be installed so the lock groove does not line up with the lock button, allowing you to install and remove die without depressing the lock button.

## YOU CAN NOW BEGIN RELOADING

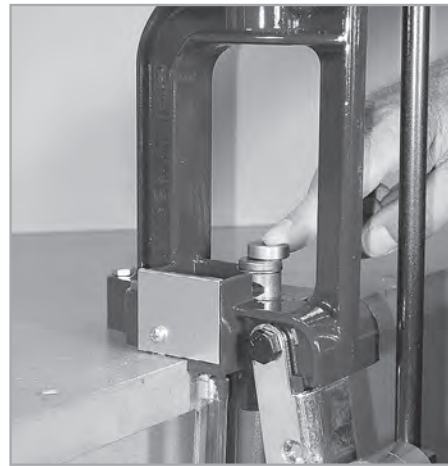

**1 INSTALL SHELLHOLDER**

**2 INSTALL SIZING DIE** While holding the handle against the stop, screw the die in until it touches the shell holder, then release pressure from the handle and screw the die in an additional  $\frac{1}{4}$  to  $\frac{1}{2}$  of a turn maximum. Now while holding the die, tighten the lock ring.

NOTE: Carbide dies should not be screwed in the additional  $\frac{1}{4}$  to  $\frac{1}{2}$  turn.



**3 PREPARE YOUR CASES** Inspect your cases while lubricating them. Discard all cases with split necks, indications of head separation or other defects. Wipe on a thin film of Lee Case Lubricant with your fingers. Fingers are the best way of lubing a case as any grit that could damage the die is wiped away. The case may be immediately sized or you can let the lube dry.



Be sure to lube the inside of the case neck with a cotton swab.

**4 PLACE** the lubricated case in the shell holder and raise the ram until the handle comes to a stop. Proceed to the priming operation. Carbide dies need no lubrication

Primer arm must be in place to direct spent primers.

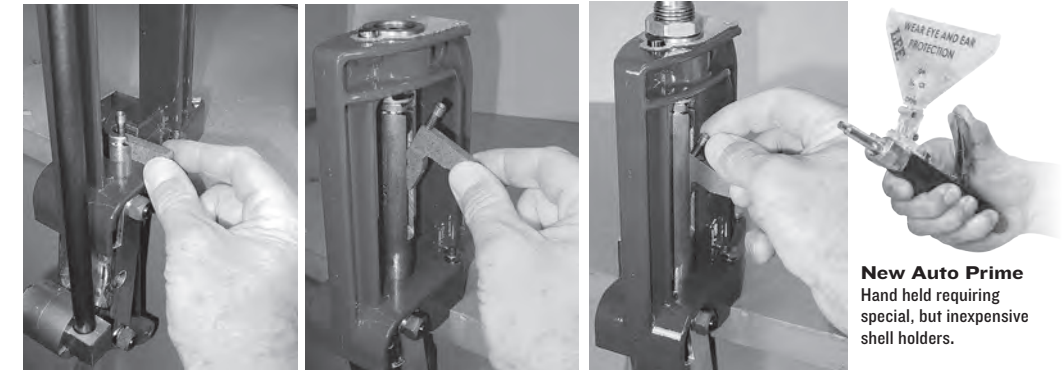

**5 PRIME YOUR CASE** using the Lever prime system or off the press using the Lee Auto Prime. Install the correct primer arm (large or small) by simply hooking the primer arm over the cross pin in the ram. Place the proper type of primer in the primer guide. Using the Safety Prime greatly speeds this operation. See panel on reverse for details on the Safety Prime System.

Lower the ram to install the primer lift hard enough to seat the primer flush with the end of the case. Primers can be seated slightly below flush but never protruding.



**6 FLARE CASE MOUTH** for ease of bullet installation. Raise the ram to expand the case neck. To increase the flare, screw the die in deeper. Always adjust to provide the minimum flare needed to start the bullet. After proper adjustment, tighten the lock ring. Powder may be added through Lee Expanding Dies.

THIS STEP IS OMITTED WITH MOST RIFLE 2-DIE SETS

**7 CHARGE THE CASE** Regardless of how you charge the case, be absolutely certain you have the correct amount and type of powder for the bullet you have selected.

NEVER try to seat the primer deeper after the powder has been added.



**8 SCREW** the bullet seating die in until you feel it touch the case mouth. If no crimp is desired, back the die out  $\frac{1}{2}$  turn. If a crimp is desired, turn the die in  $\frac{1}{4}$  turn.

**9 SEAT THE BULLET** Place a bullet on the case mouth and guide it into the die. Raise the ram to the top and withdraw. The knurled adjusting screw controls the bullet seating depth. Adjust to suit. Usually, seating to the same depth as a factory round works fine. If you desire to crimp, be sure the bullet crimp groove is almost completely inside the case. Then screw the die in just enough to apply a good crimp. Attempts to apply excessive crimp will crush the case. For proper crimp, all cases must be trimmed to the same length. For best utility and accuracy, consider the Lee Factory Crimp Die. You will never crush a case; no crimp groove is required and trim length is not critical.



Lee Factory Crimp Die



**10 IF LOADING** maximum loads, it is a good practice to remove all traces of case lubricant with detergent and water. This will reduce pressure against the bolt.



**IT IS YOUR RESPONSIBILITY TO ENSURE THE SAFETY OF YOUR LOADS**

THE FOLLOWING ARE FACTORS THAT WILL INCREASE PRESSURES. SOME WILL BE DANGEROUS.

- **DO NOT USE** more powder than recommended
- **DO NOT USE** a heavier bullet than recommended
- **DO NOT SEAT** the bullet deeper than normal
- **DO NOT USE** magnum primers unless using a slow burning ball powder
- **Greatly oversize bullets, excessively hard bullets or cases that are too long will cause higher pressures**
- **High temperatures, or cartridges that were stored in a hot car or car trunk will produce higher pressures**

**CROSS SECTION OF A TYPICAL CARTRIDGE**

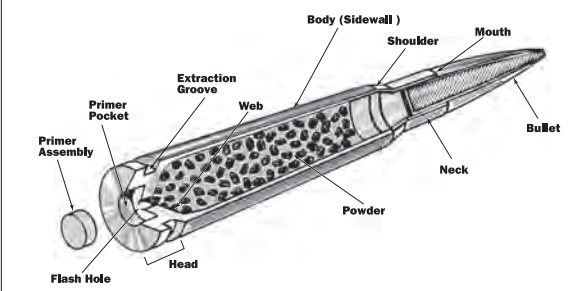

**RELOADING SAFETY**

- Keep powder away from heat and open flames — Don't smoke
- Store powder and primers in their original containers in a cool, dry place
- Read and follow instructions exactly
- Be sure you have the correct powder, measure and bullet of the correct weight. Any mixup can be dangerous
- Exercise care and common sense at all times

**WEAR SAFETY GLASSES & HEARING PROTECTION WHEN RELOADING OR SHOOTING**

**RELOADING IS QUITE A SIMPLE PROCESS**

- 1 Case is sized to original dimensions and the spent primer is removed
- 2 Install a new primer
- 3 Add a charge of powder
- 4 Seat a new bullet and crimp if desired

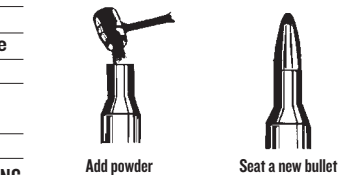

**CASES**

The easiest and best way of getting cases is to simply save those from your factory loaded rounds. New and used cases can also be purchased. Cases must be clean and safe. Do not use cases that have cracks or splits. If they have been used more than twice, they should be checked to see that none of them have become too long for safe use. The easiest way is to trim them with a Lee Case Trimmer. This automatically cuts them to the correct length and no gauging or measuring is needed. After trimming, be sure to chamfer both the inside and outside of the case. A Lee Chamfer Tool works best, but it can be done with a pocket knife.

Straight sided cases, such as those used by most handguns, are loaded with a 3-die set.

**MILITARY CASES**

Used military cases are readily available at low cost. Usually, these have primers that are crimped in place. This is to prevent the primer from coming loose in automatic weapons and jamming the action at an inopportune time. The crimp must be removed before repriming. This can be done with a primer pocket reamer or swaging tool. Even a Lee Chamfer Tool can be used to ream the crimp.

**POWDER**

Powder is usually classified as smokeless and black powder. There is also Pyrodex, which is a substitute for black powder. We will be using only smokeless powder for reloading.

Each set of Lee Dies is supplied with powder measure and charge table with a generous selection of loads. Additional load data is available from all the powder manufacturers and bullet makers. This is excellent information and should be followed exactly.

Different powders are available to do different jobs. Bullets having a high sectional density (long length in relation to their diameter) require a slow burning powder. This permits sustained peak pressure to gain maximum acceleration within working pressure limits. Short, light bullets use quicker burning powder for complete combustion within the barrel. A wide selection of powder is readily available. Powders should always be stored in their original containers. While smokeless powder is not an explosive and not as dangerous to handle as

gasoline, it would be foolish to handle it carelessly and store excessive amounts. Follow the powder manufacturers' recommendations for storage and use.

**PRIMERS**

Rifle and pistol cartridges require different primers. Rifle primers have a thick and stronger cup to withstand the higher pressure. Pistol primers have a thinner cup for easy detonation with a lighter hammer blow. Both rifle and pistol primers are available in regular and magnum. Use regular for all loads except if the load data specifies magnum primers.

Primers must always be stored in their original containers. It is always a wise idea to wear safety or shooting glasses when shooting or reloading.

**BULLETS**

Commercial rifle bullets usually have a soft lead core with a copper jacket. Point shapes come in a variety of styles, but usually have some soft lead exposed to properly mushroom on impact.

The jackets serve a dual purpose: to control the bullet expansion and act as a bearing surface for its high speed travel down the bore. Some bullets have a crimping groove called a cannelure. This groove must be seated almost entirely in the case when crimping the case. The very end of the case mouth is turned into this groove by the bullet seating die used in a tubular magazine gun and most revolver ammunition.

Cast bullets are very popular with the handloader. They are very economical to use and can be as accurate as jacketed bullets. They do not normally expand as well as soft lead jacketed bullets on game. Therefore, it is poor economy to use them for hunting.

**CRIMPING**

Ammunition loaded for hunting should always have the bullets crimped in place, as should ammunition used in tubular magazine and auto-loading rifles. It could ruin your hunt if a bullet wedged in the chamber or pushed back into the case. Best accuracy is usually obtained with crimped ammo as the crimp has an effect on ignition, velocity, pressure and ballistic consistency. No die does a better job crimping than the patented Lee Factory Crimp Die.

**SAFETY PRIMER FEED INSTRUCTIONS**

**ALL BRANDS OF PRIMERS ACCEPTED**

Patent # 7,084,618, Expires October 30, 2027

**PRIMERS WILL EXPLODE IF SHOCKED OR CRUSHED**  
**WEAR EYE & EAR PROTECTION AT ALL TIMES WHEN HANDLING PRIMERS**  
**WARNING**

Primer dust accumulation can detonate. Regularly clean tray and tool to prevent accumulation. The dust contains lead; a substance known to cause birth defects, reproduction harm and other serious physical injury. Wash hands after exposure.

- 1 **INSTALL** primer feed bracket. Use supplied 10-24 screws.

**SINGLE STAGE PRESS**

- 2 **VERIFY** appropriate primer arm and trigger assembly are installed.



- 3 **MAKE** sure trough fingers are between and completely engaged with tray latch lugs (highlighted)

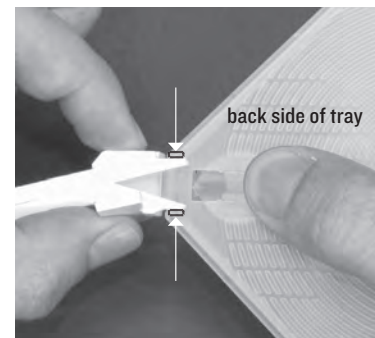

- 4 **OPEN** tray and deposit box of 100 primers.



- 5 **SHAKE** tray side to side to upright all the primers. Fold and close cover and slide to ON position. Shake assembly to fill the trough.

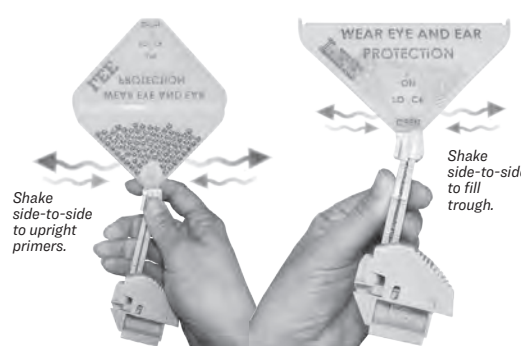

- 6 **SLIDE** primer feed into primer feed bracket.



- 7 **Firmly** push trigger on the primer feed to dispense primer.



- 8 **LOWER** ram to seat primer. The primer should be flush, to slightly below flush, when properly seated.



**LEE**  
LEE PRECISION, INC. 4275 HWY. U  
HARTFORD, WISCONSIN 53027  
www.leeprecision.com

**LEE COMPLETE INSTRUCTIONS**

**Breech Lock CHALLENGER**

MADE IN USA

**LOCK RING WRENCH INCLUDED**



Works on Spline Drive Breech Lock Bushings and Spline Drive Lock Rings

**BREECH LOCK BUSHINGS** fit all Lee Breech Lock presses. Allows instant, accurate die changes.

**ACCESSORY**



**SPLINE DRIVE LOCK RINGS** 90063 Breech lock quick change bushing with integral lock collar provides unmatched precision and convenience when adjusting dies.



**QUICK LOCK BUSHING** [one included] 90600 Perfect with Lee Lock Rings



**LOCK PIN** OF3615

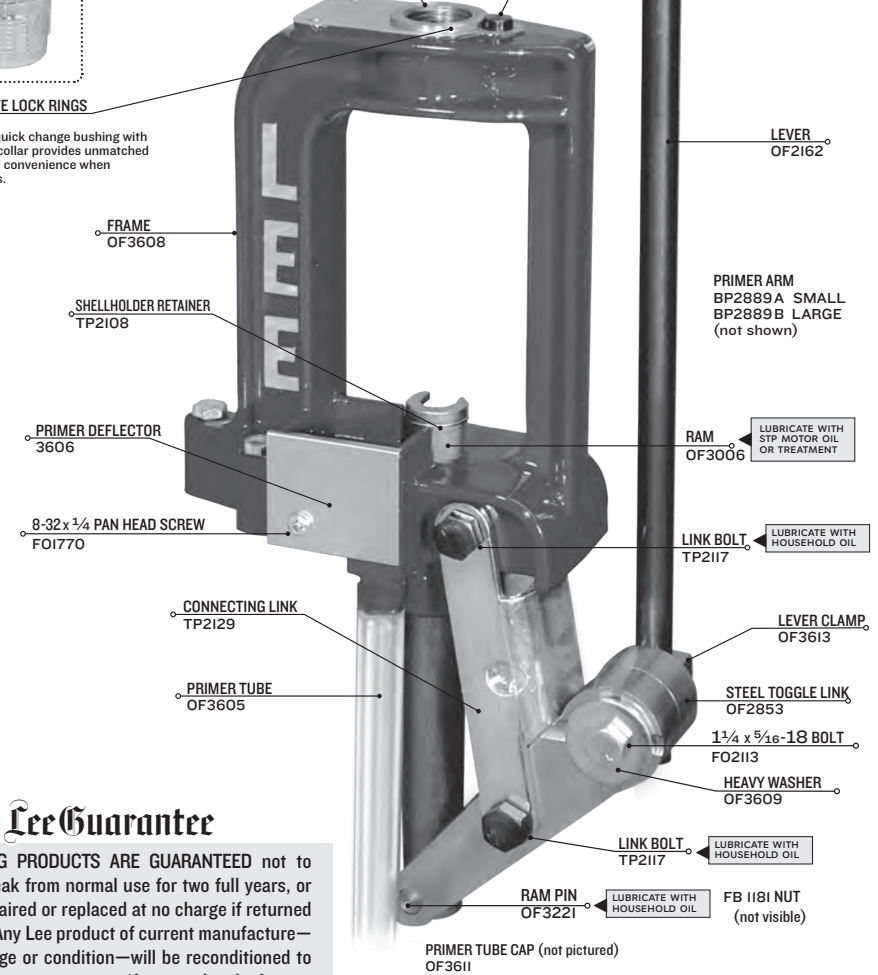

**The Lee Guarantee**

LEE RELOADING PRODUCTS ARE GUARANTEED not to wear out or break from normal use for two full years, or they will be repaired or replaced at no charge if returned to the factory. Any Lee product of current manufacture—regardless of age or condition—will be reconditioned to new, including a new guarantee, if returned to the factory with payment equal to half the current retail price.

**CAUTION**

Ammunition reloading can be dangerous if done improperly and should not be attempted by persons not willing and able to read and follow instructions exactly. Children should not be permitted to reload ammunition without strict parental supervision. Always wear safety glasses when reloading and shooting. Ammunition loaded with these tools and data should only be used in modern guns in good condition. We do not accept responsibility for ammunition loaded with these tools or data as we have no control over the manufacture and storage of components or the loading procedure and techniques. Primers and gun powders, like gasoline and matches, can be dangerous if improperly handled or misused.



**WARNING** Handling live primers and spent primers may expose you to lead or other chemicals, which are known to the State of California to cause reproductive harm and cancer. For more information, go to [www.P65Warnings.ca.gov](http://www.P65Warnings.ca.gov).



**WARNING** Steel parts in this product may be alloyed with trace amounts of lead and other elements which are known to the State of California to cause reproductive harm and cancer. For more information, go to [www.P65Warnings.ca.gov](http://www.P65Warnings.ca.gov). To prevent exposure, do not alter the product by welding, grinding, etc.

OF1219

© 2021 Lee Precision Inc. Printed in USA

**LEE** LEE PRECISION, INC.  
4275 Hwy U · Hartford WI 53027  
www.leeprecision.com